

Service Schematics

NOKIA N80

Introduction

IMPORTANT:

This document is intended for use by authorized NOKIA service centers only.

“Service Schematics” was created with focus on customer care. The purpose of this document is to provide further technical repair information for NOKIA mobile phones on Level 3/4 service activities. It contains additional information such as e.g. “Component finder”, “Frequency band table” or “Antenna switch table”. The “Signal overview” page gives a good and fast overview about the most important signals and voltages on board. Saving process time and improving the repair quality is the aim of this document. It is to be used additionally to the service manual and other training or service information such as Service Bulletins.

All measurements were made using following equipment:

Nokia repair SW	: Phoenix version 2005.36.10.115
Oscilloscope	: Fluke PM 3380A/B
Spectrum Analyzer	: Advantest R3162 with an analog probe
RF-Generator / GSM Tester	: Rhode & Schwarz CMU 200
Multimeter	: Fluke 73 Series II

While every endeavour has been made to ensure the accuracy of this document, some errors may exist. If the reader finds any errors, NOKIA shall be notified in writing.

Please send E-Mail to: training.sace@nokia.com

Copyright © NOKIA

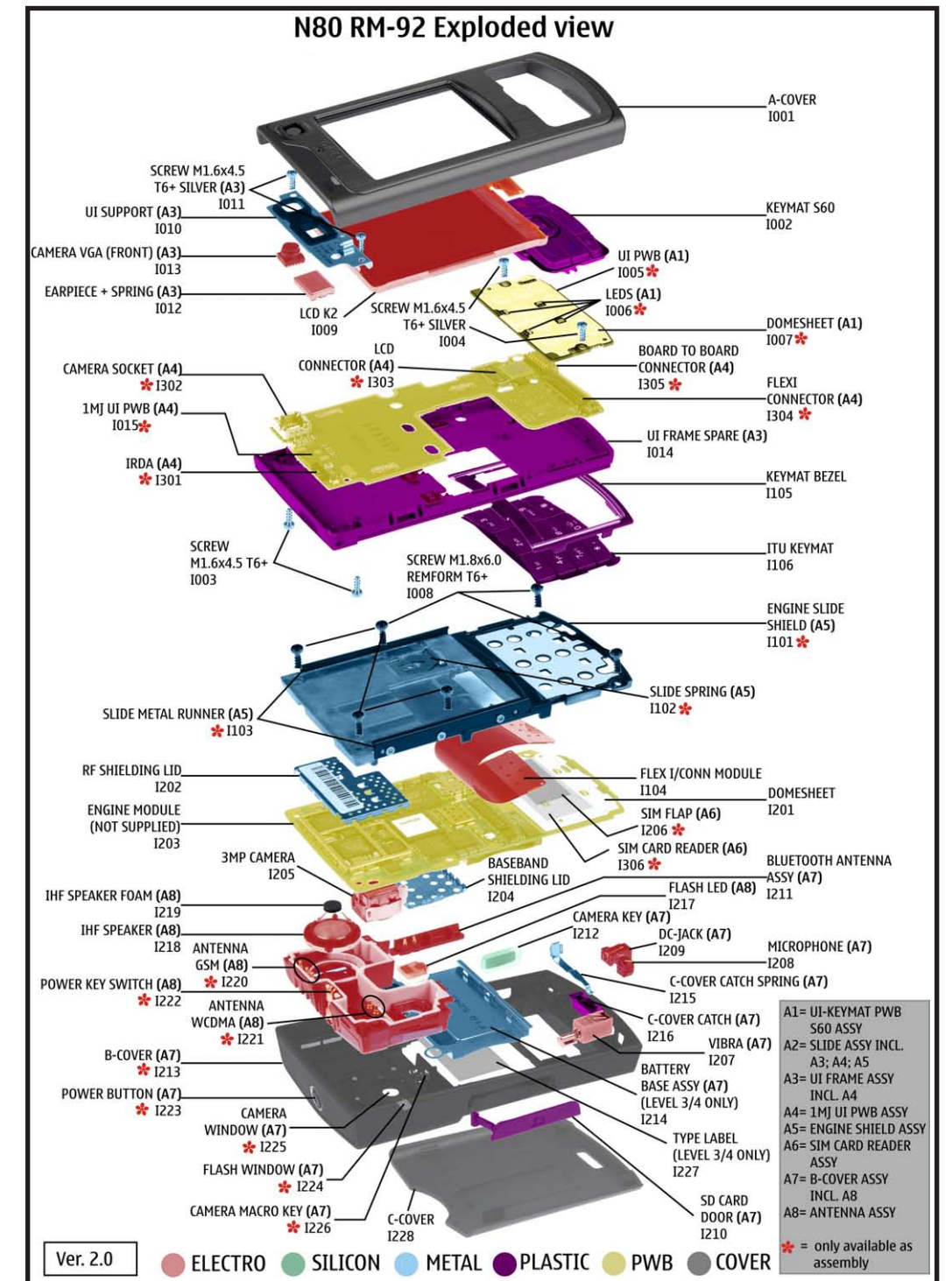
This material, including documentation and any related computer programs is protected by copyright, controlled by NOKIA. All rights are reserved. Copying, including reproducing, modifying, storing, adapting or translating any or all of this material requires the prior written consent of NOKIA. This material also contains company confidential information, which may not be disclosed to others without the prior written consent of NOKIA.

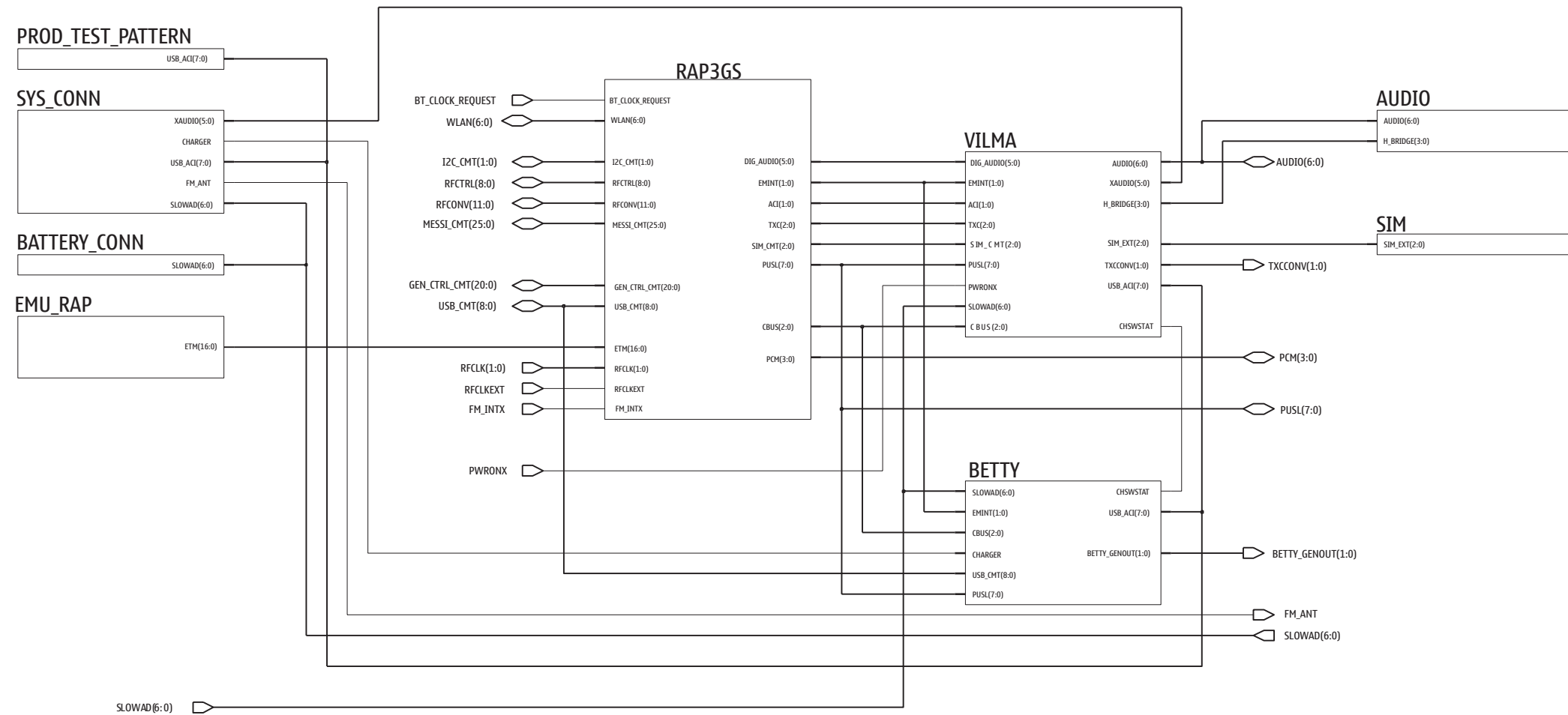
RM-92

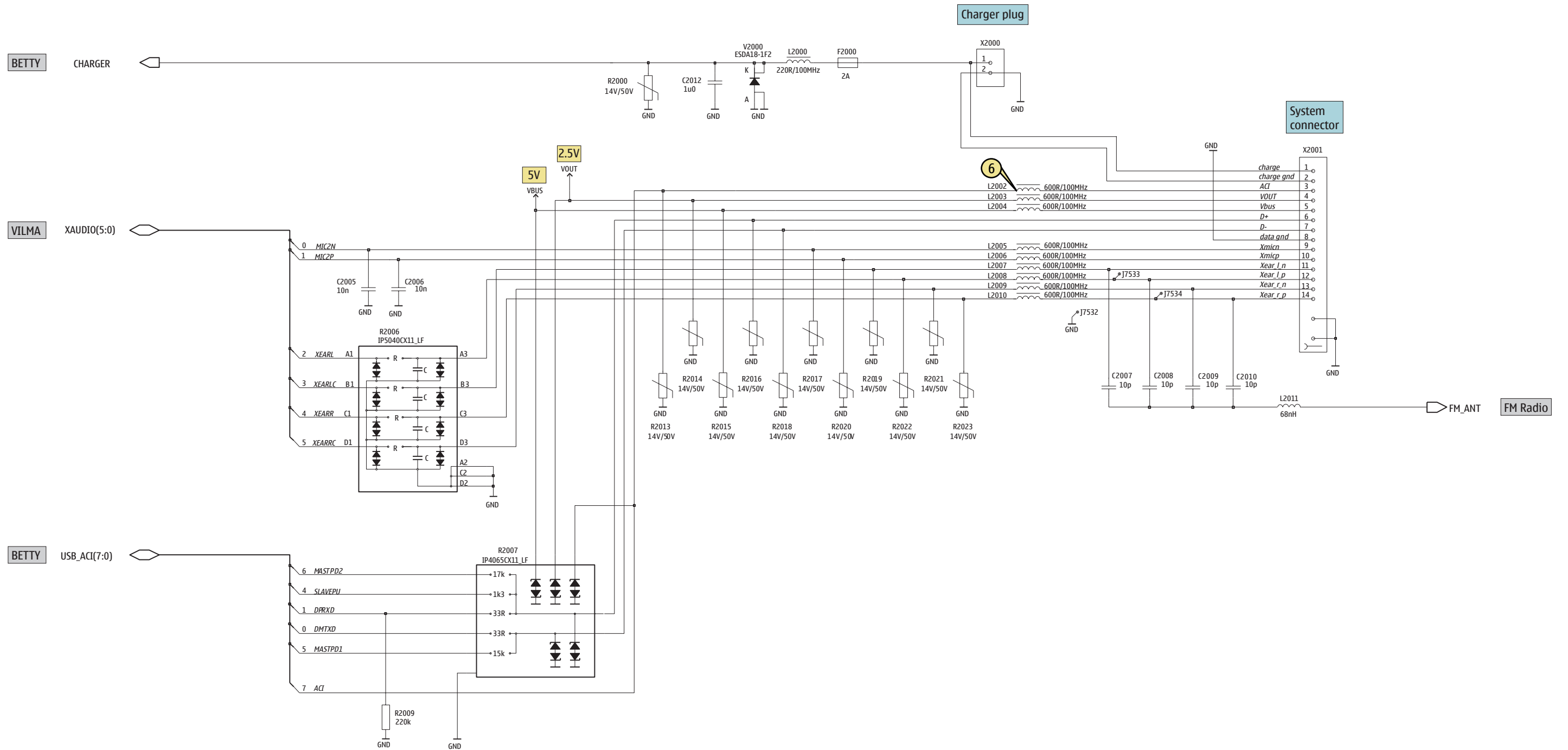


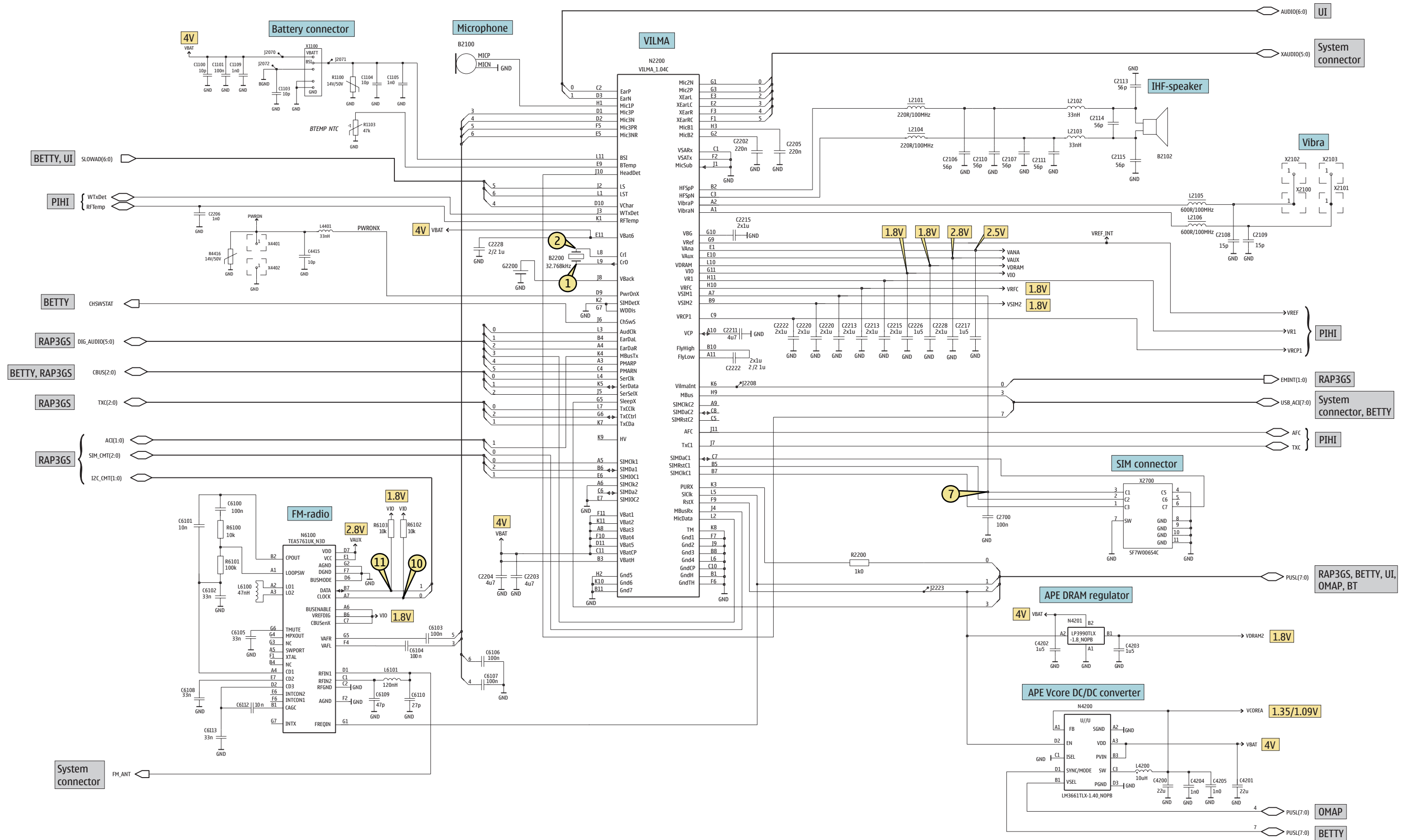
Table of Contents	Page
Front page	1
BB connetions	2
System connector	3
VILMA, SIM, Audio	4
BETTY	5
RAPG3S	6
OMAP, Combo memory, mini SD, SDRAM, back camera	7
BT, WLAN	8
UI	9
UI- module	10
RF- part	11
Signal overview	12
Component finder	13

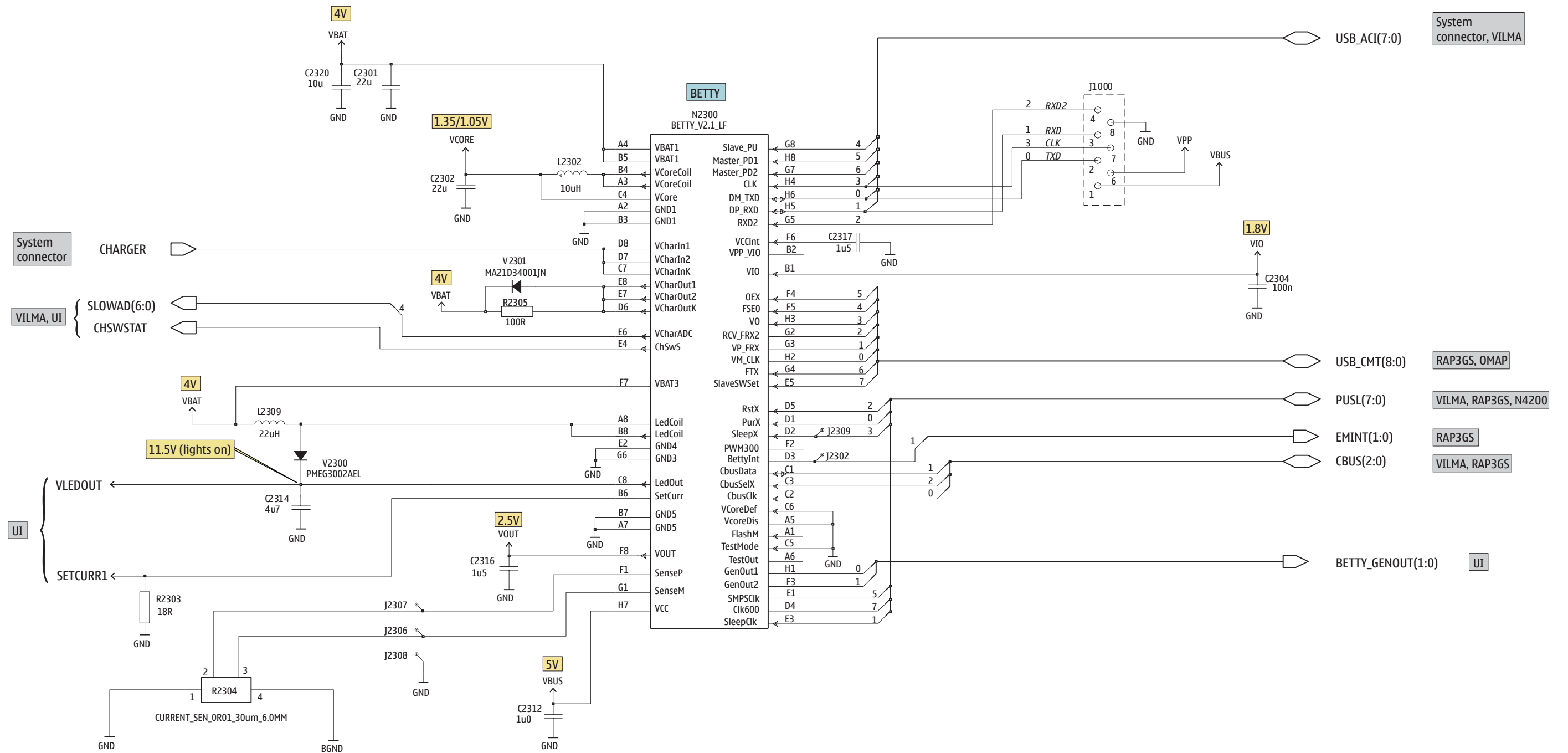
Exploded view and component disposal

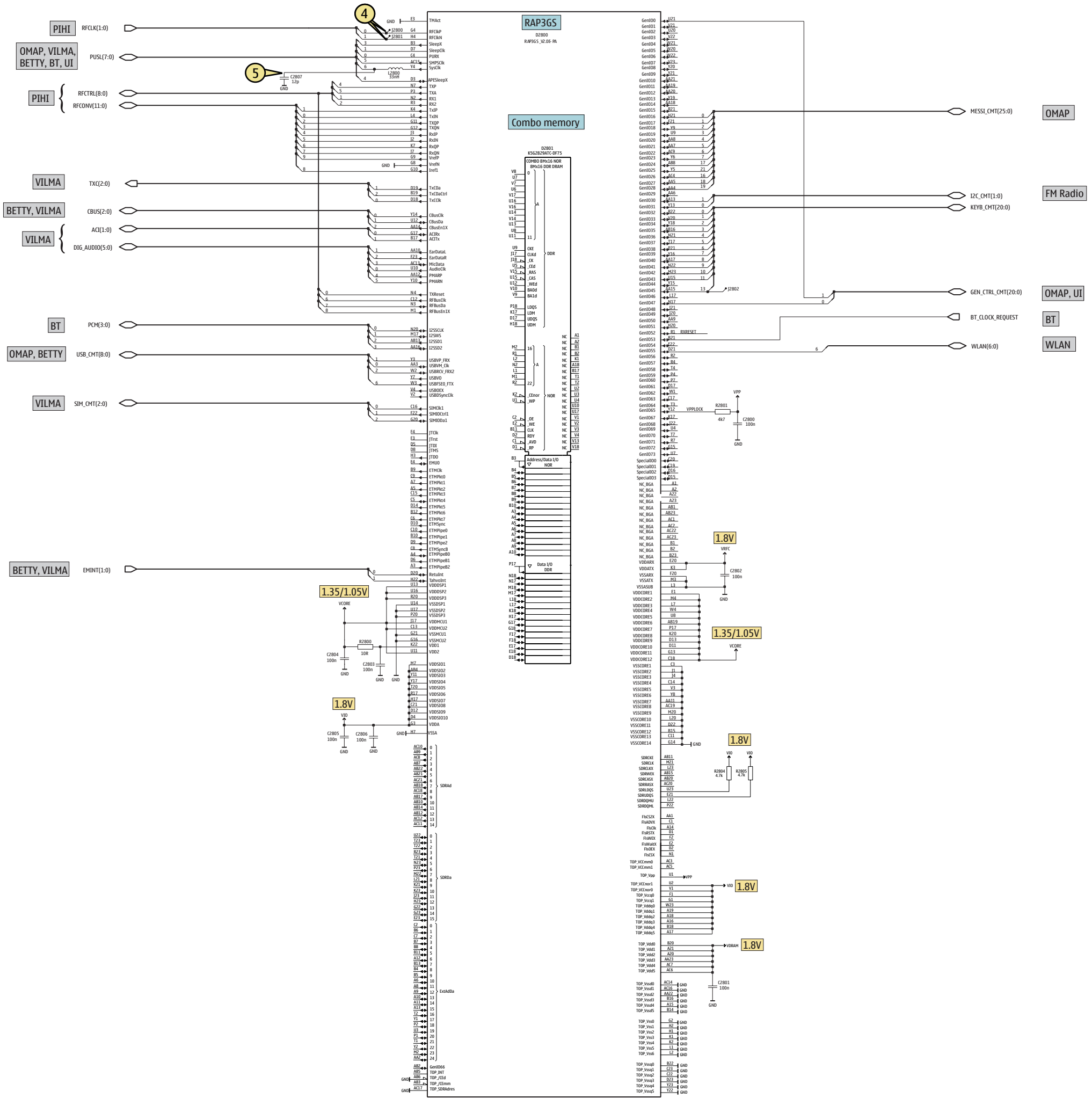


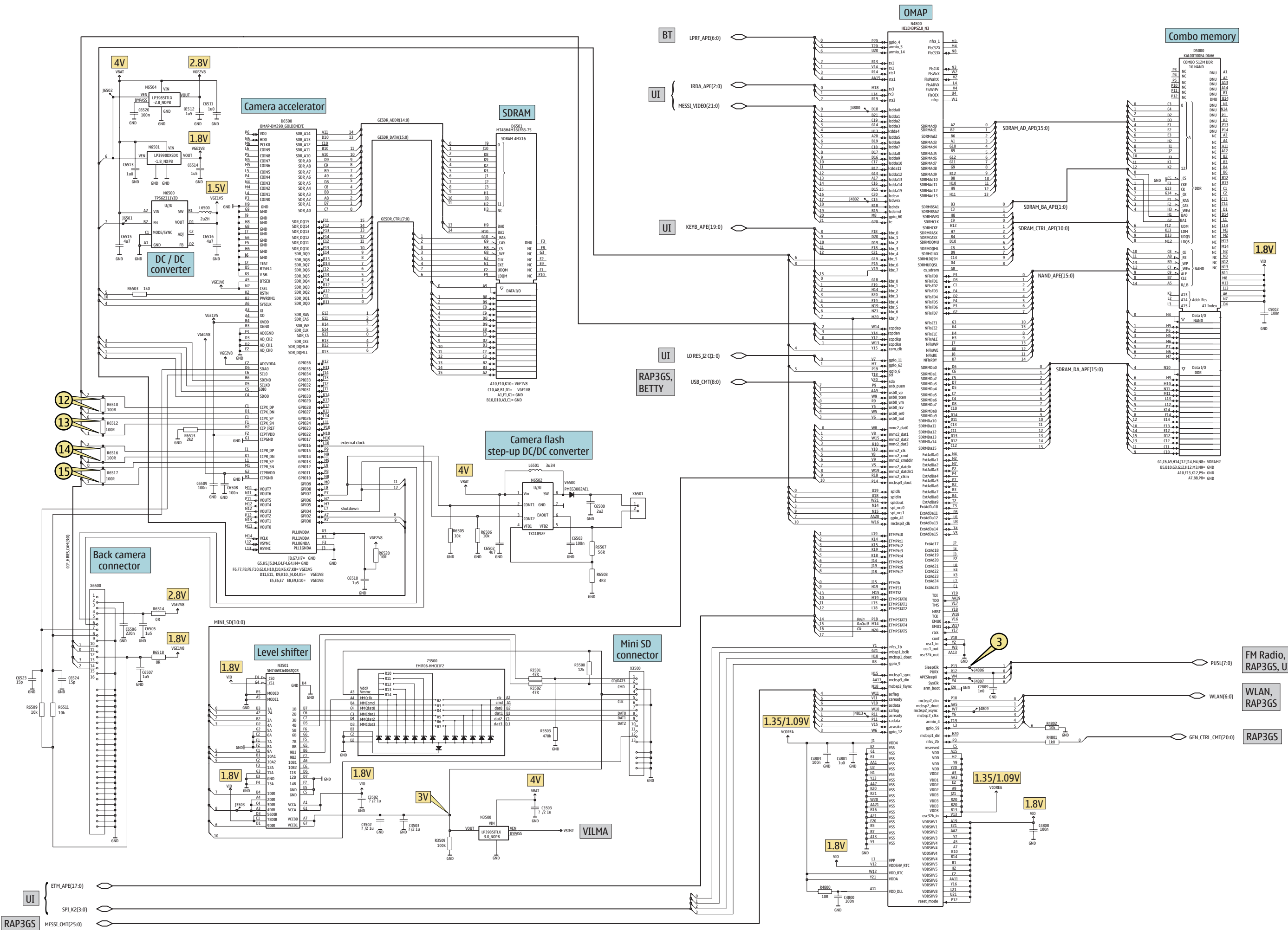


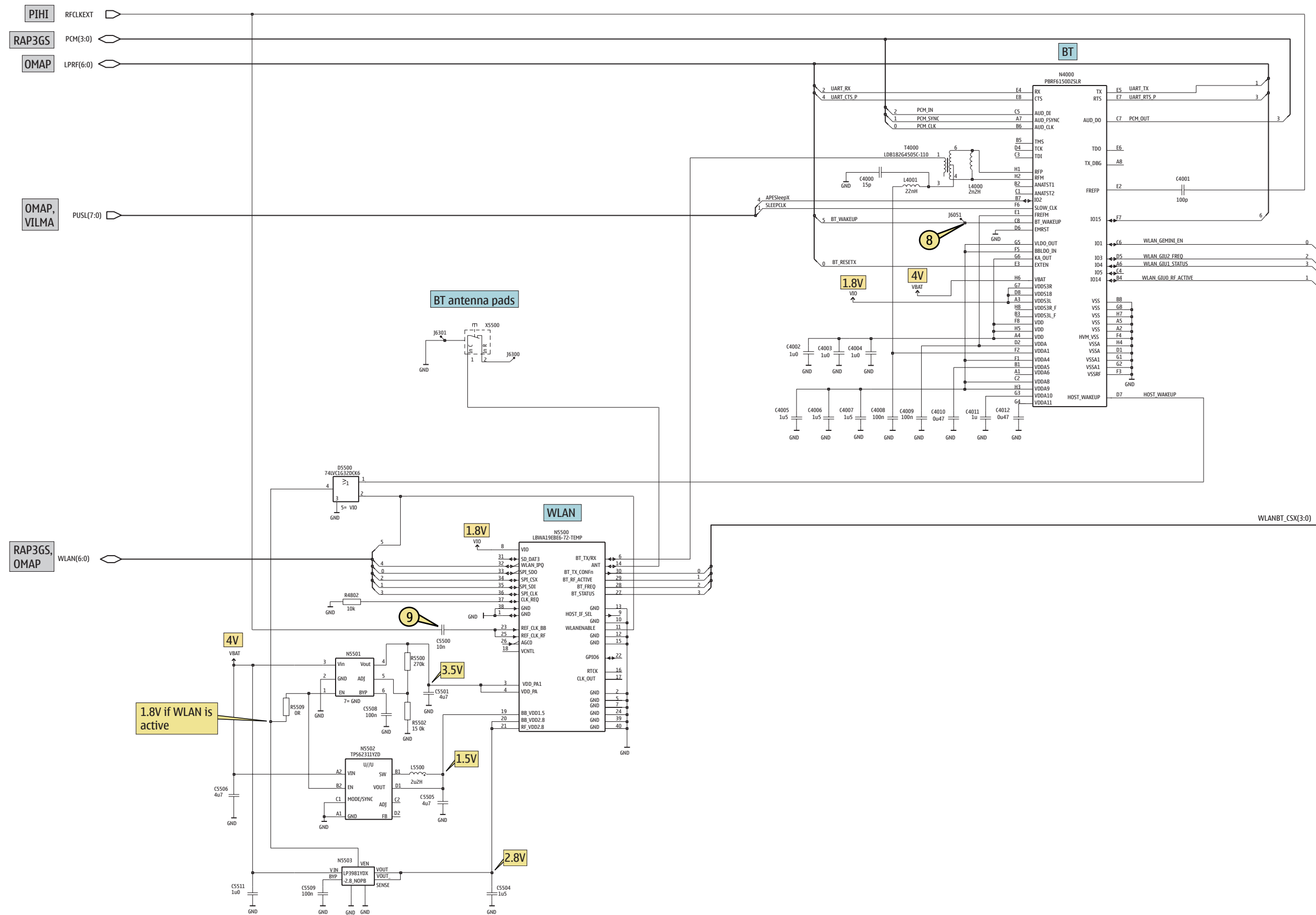


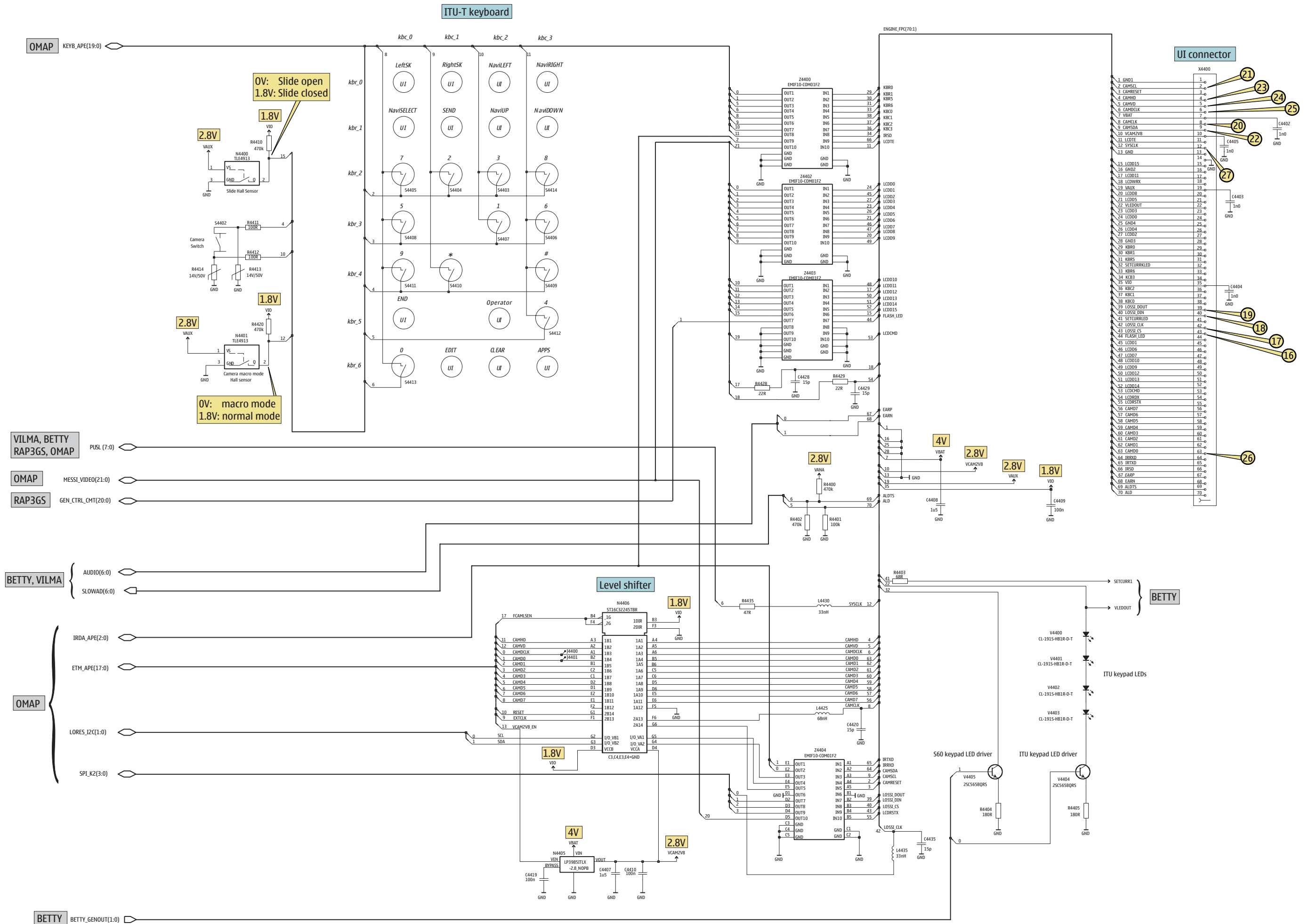


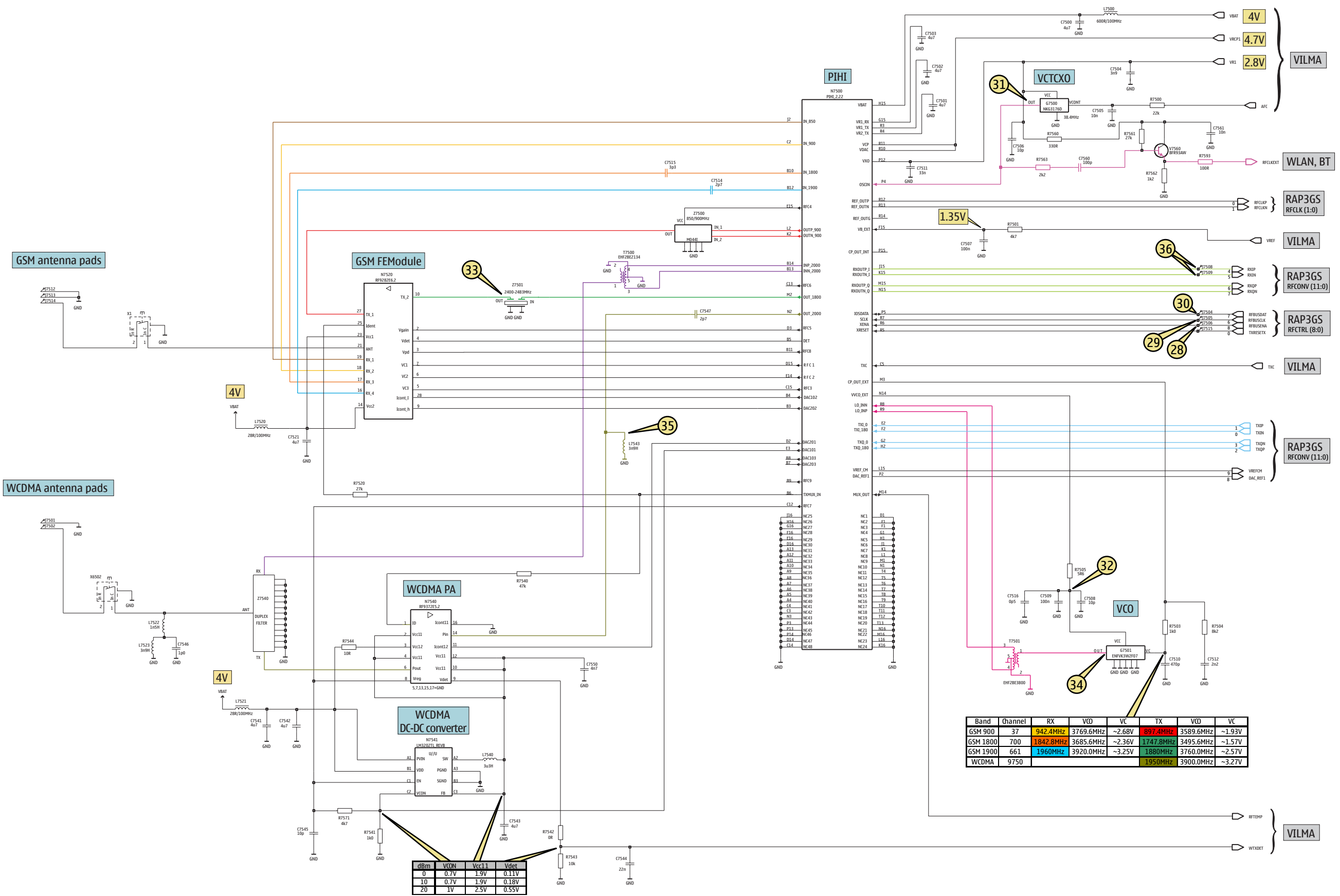


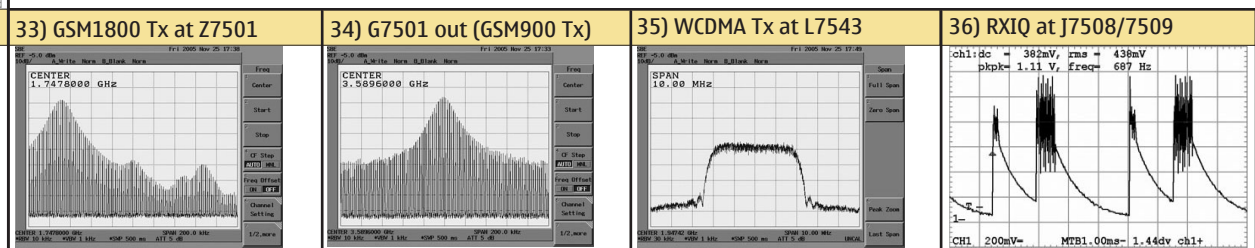
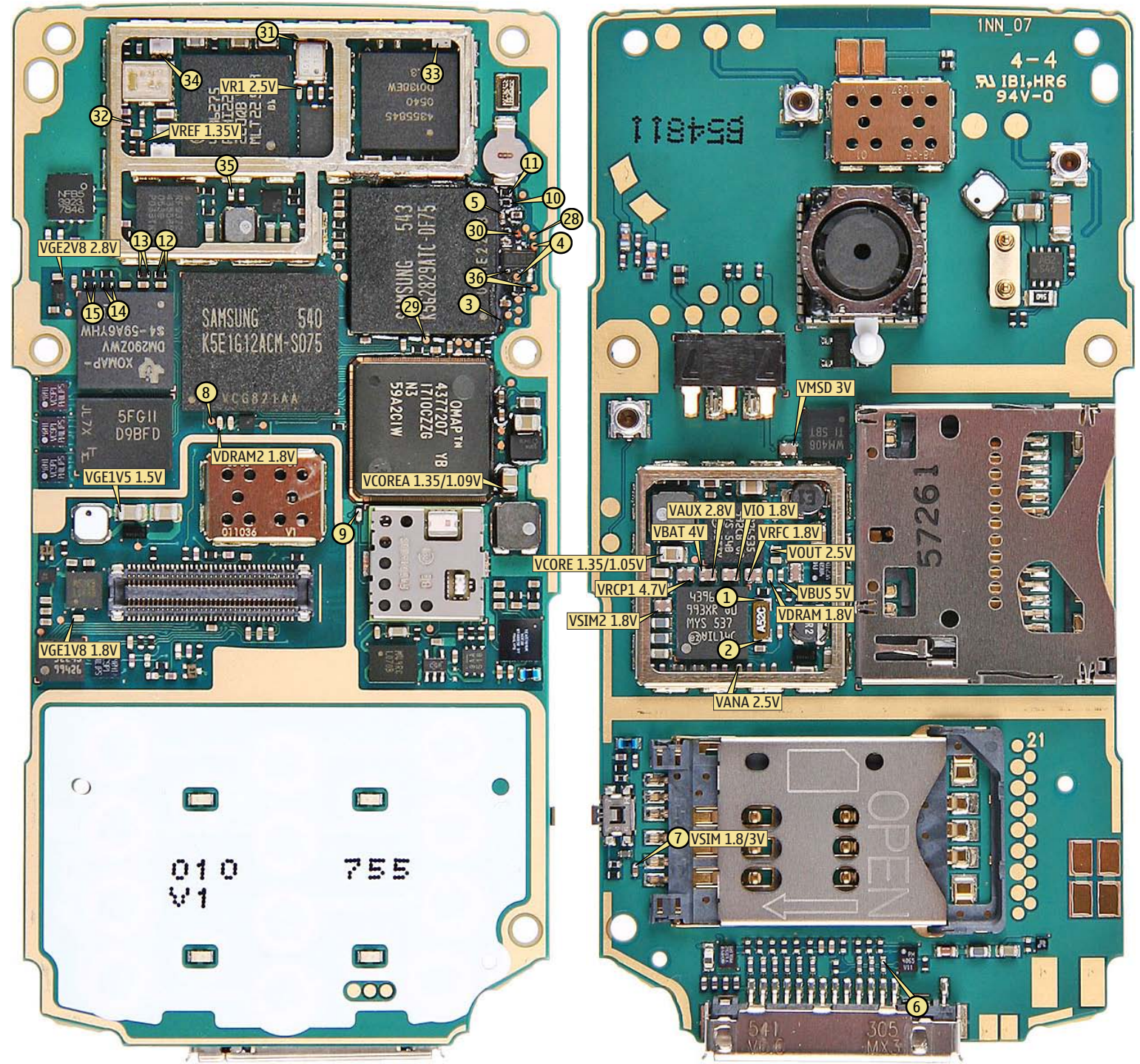
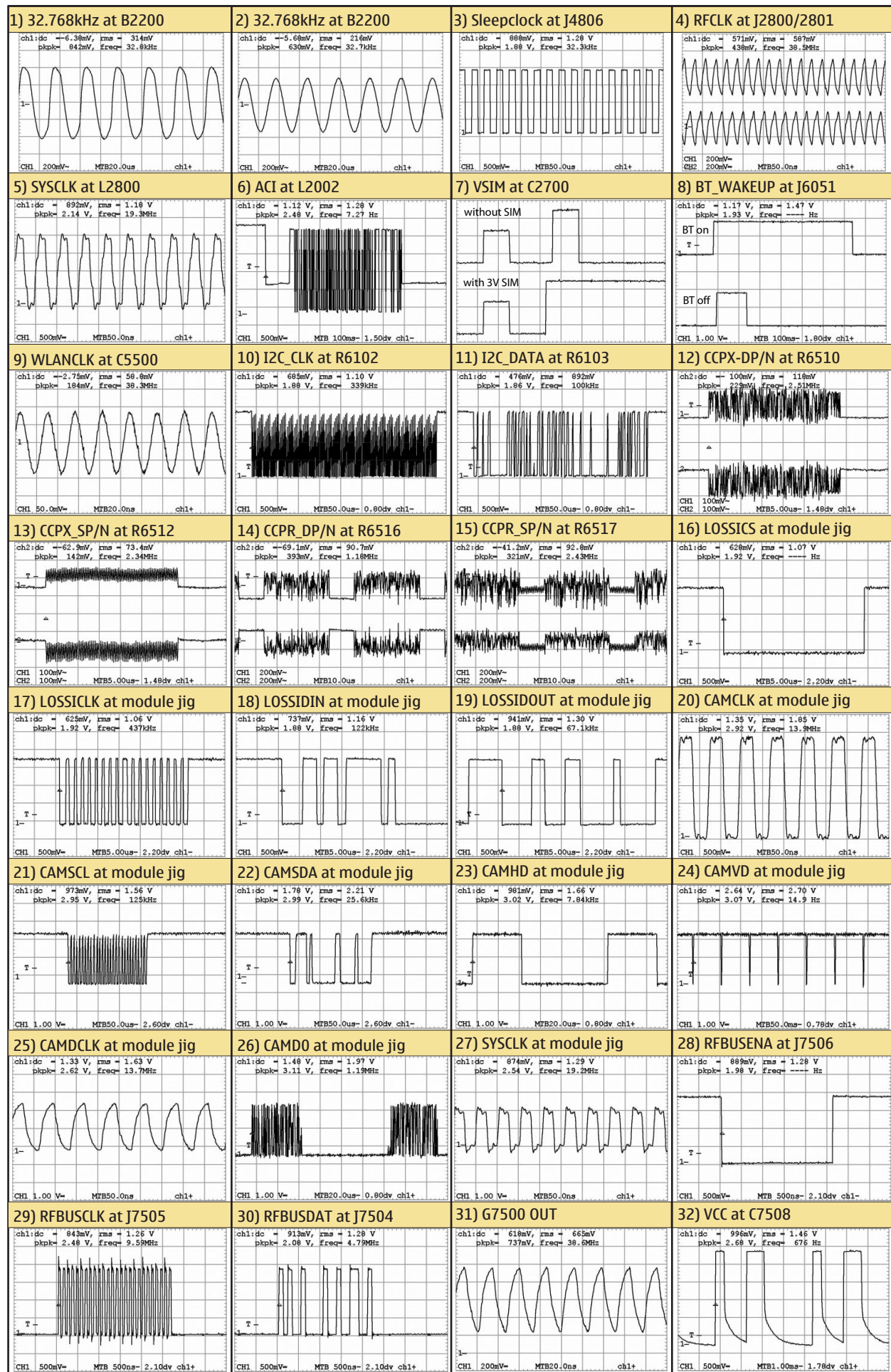












B	C4004	D10	C6511	B13	L2102	I14	R2015	E2	R7500	F16	
B2200	G8	C4005	E9	C6512	A13	L2103	I14	R2016	E2	R7501	B16
C	C4006	D10	C6513	A9	L2104	H8	R2017	F2	R7503	B17	
C1100	H14	C4007	D9	C6514	B8	L2105	H7	R2018	F2	R7504	D17
C1101	H13	C4008	E9	C6515	C9	L2106	H7	R2019	F2	R7505	B16
C1103	G13	C4009	D9	C6516	B9	L2302	H9	R2020	F2	R7520	G15
C1104	G13	C4010	D9	C6520	A13	L2309	F10	R2021	G2	R7540	D15
C1105	G11	C4011	E10	C6523	D16	L2800	I14	R2022	G2	R7541	E15
C1109	H11	C4012	E10	C6524	E16	L4000	E9	R2023	G2	R7542	B14
C2005	F2	C4200	I10	C7500	C16	L4001	E10	R2200	H10	R7543	E15
C2006	F2	C4201	I11	C7501	D17	L4200	I9	R2303	G10	R7544	D14
C2007	H2	C4202	D11	C7502	E17	L4401	D17	R2305	G9	R7560	E16
C2008	H2	C4203	D11	C7503	C16	L4425	C7	R2800	F14	R7561	E16
C2009	G2	C4204	H10	C7504	E16	L4430	C7	R2801	I14	R7562	D16
C2010	G2	C4205	G12	C7505	F16	L4435	C7	R2804	F14	R7563	E16
C2012	C2	C4402	E7	C7506	E16	L5500	F8	R2805	F14	R7571	E15
C2106	I7	C4403	D8	C7507	C16	L6100	I7	R3500	F8	R7593	D16
C2107	H7	C4404	B7	C7508	B16	L6101	I6	R3501	F8	S	
C2108	G7	C4405	D7	C7509	C16	L6500	B9	R3502	F8	S4402	I4
C2109	H7	C4407	A8	C7510	C17	L6501	C15	R3503	F8	T	
C2110	I14	C4408	E7	C7511	E16	L7500	C16	R3509	G8	T4000	E9
C2111	I13	C4409	A8	C7512	D17	L7520	G15	R4400	C7	T7500	C15
C2113	I14	C4410	A8	C7514	F17	L7521	E14	R4401	E9	T7501	C17
C2114	I14	C4418	D9	C7515	F17	L7522	A14	R4402	C7	V	
C2115	H14	C4419	B9	C7516	B16	L7523	A14	R4403	C9	V2000	B2
C2202	G7	C4420	C7	C7521	F15	L7540	D14	R4404	A9	V2300	G10
C2203	H8	C4428	D9	C7541	E14	L7543	D15	R4405	D7	V2301	F9
C2204	H7	C4429	D9	C7542	E14	N	R4410	I13	V4400	F5	
C2205	G7	C4435	B7	C7543	D14	N2200	H8	R4411	I5	V4401	F2
C2206	F7	C4800	H12	C7544	E14	N2300	G9	R4412	I3	V4402	D2
C2211	H8	C4801	I11	C7545	B14	N3500	F9	R4413	I5	V4403	D5
C2213	G8	C4803	I11	C7546	B14	N3501	F10	R4414	I4	V4404	C7
C2215	G8	C4808	I11	C7547	D15	N4000	F11	R4416	D17	V4405	A9
C2217	G7	C5002	H12	C7550	B14	N4200	I11	R4420	E12	V6500	B15
C2220	H8	C5500	F9	C7560	E16	N4201	D11	R4428	D9	V7560	D16
C2222	H8	C5501	G7	C7561	E16	N4400	I14	R4429	C9	X	
C2226	G8	C5504	G7	D	N4401	E12	R4435	C7	X1	F16	
C2228	H8	C5505	F7	D2800	G14	N4405	A8	R4800	G12	X1000	I16
C2301	F9	C5506	F7	D2801	G14	N4406	A7	R4801	F11	X1100	G12
C2302	H9	C5508	H7	D5000	E12	N4800	G11	R4802	H12	X2001	F1
C2304	H10	C5509	H7	D5500	H7	N5500	G9	R5500	H7	X2100	A4
C2312	F8	C5511	H7	D6500	B12	N5501	H7	R5502	H7	X2101	A4
C2314	G10	C6100	I8	D6501	B11	N5502	F7	R5509	G7	X2102	A3
C2316	G9	C6101	I8	F	N5503	G7	R6100	I8	X2103	A3	
C2317	G9	C6102	I8	F2000	D2	N6100	I7	R6101	I8	X2700	F4
C2320	H10	C6103	I8	G	N6500	C9	R6102	I15	X3500	C9	
C2700	I3	C6104	H7	G2200	I15	N6501	B8	R6103	I15	X4400	D8
C2800	I14	C6105	I7	G7500	E17	N6502	B14	R6503	D16	X4401	E17
C2801	F15	C6106	G7	G7501	C17	N6504	A13	R6505	C13	X4402	E17
C2802	F12	C6107	G7	L	N7500	D16	R6506	B13	X5500	I11	
C2803	F14	C6108	I7	L2000	C2	N7520	G16	R6507	B13	X6500	E14
C2804	I13	C6109	I5	L2002	E2	N7540	C14	R6508	B14	X6501	C14
C2805	F14	C6110	I5	L2003	E2	N7541	E15	R6509	E16	X6502	B15
C2806	F15	C6112	I8	L2004	E2	R	R6510	C13	Z		
C2807	I14	C6113	I8	L2005	F2	R1100	G13	R6511	E16	Z3500	F8
C2809	H12	C6500	B14	L2006	F2	R1103	I4	R6512	C13	Z4400	A10
C3502	F10	C6502	B14	L2007	F2	R2000	G2	R6513	B13	Z4402	A11
C3503	F8	C6503	B14	L2008	G2	R2006	B2	R6514	D16	Z4403	A11
C4000	E10	C6506	E16	L2009	G2	R2007	D2	R6516	B13	Z4404	B7
C4001	E10	C6508	C13	L2010	G2	R2009	D2	R6517	B13	Z7500	F16
C4002	E10	C6509	C13	L2011	H2	R2013	E2	R6518	D16	Z7501	H17
C4003	E10	C6510	B13	L2101	H7	R2014	E2	R6520	B13	Z7540	A15

